

NHX

Nurse Call System

NH-1SA-AC-BLU, NH-1SA-ACB-BLU Code Blue Station, NHR-7A-CB1, NHR-7A-CB2 Code Blue Call Switch

- INSTRUCTIONS -

The models listed above have been modified to allow the Blue Call button (NHR-7A-CB) to activate the highest priority call on the NHX Nurse Call System. When the Blue switch is pushed down to the lower position, the master station will indicate the call with a fast intermittent call tone and flashing LED. The call can be cancelled only by raising the switch to the upper position. All other call levels remain the same.

WIRING DIAGRAM:

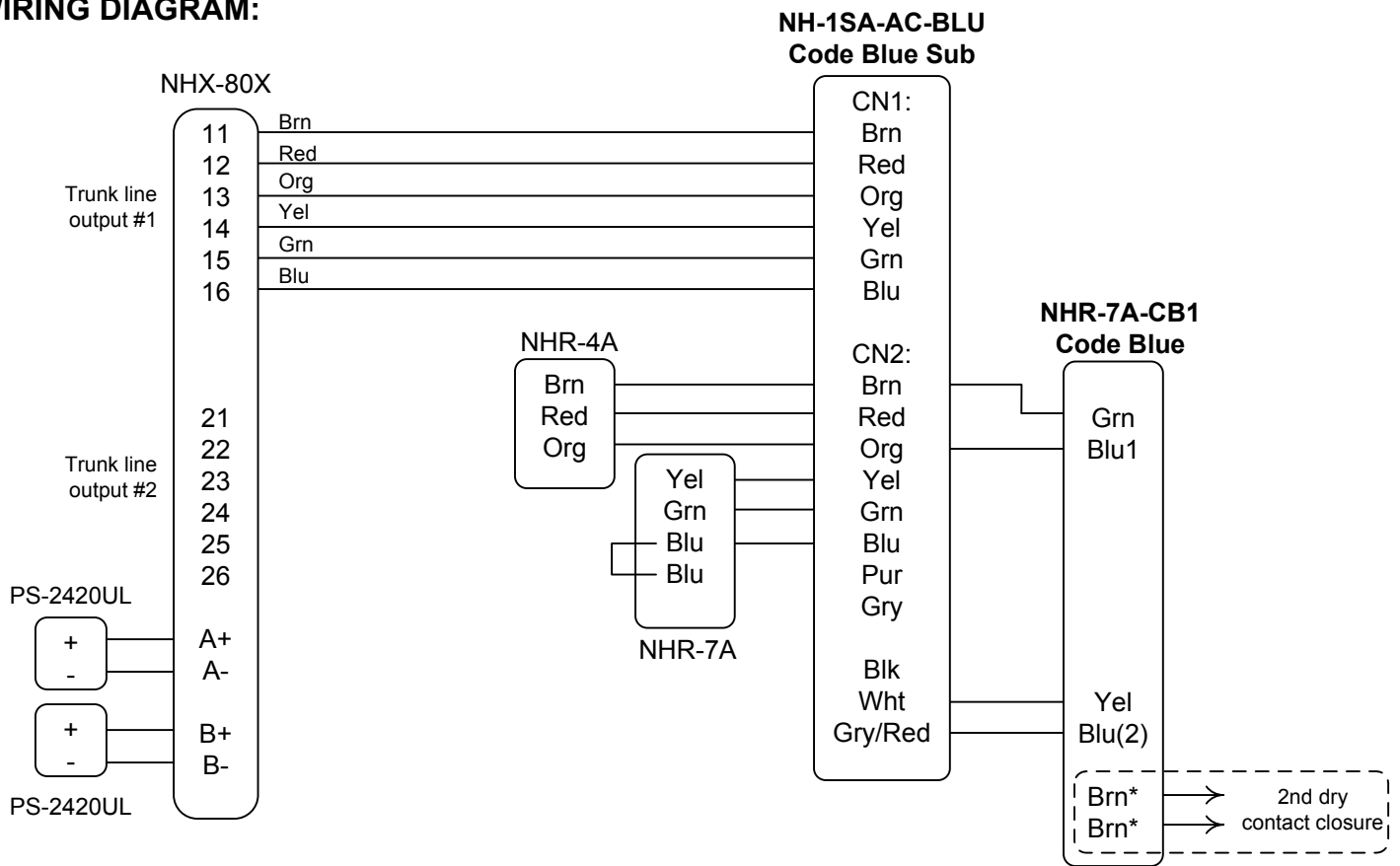

NOTES:

1. The NH-1SA-ACB-BLU wires the same as the station shown above.
2. NHR-7A-CB1 is a Code Blue station includes one set of contacts (SPST).
3. The NHR-7A-CB2 model includes two dry contact closures (DPDT, BRN wires).
4. Black wire from NH-1SA-AC-BLU is only used in systems with All Call.
5. See operational instructions for the system following on page two of this instruction sheet.
6. Only wiring concerning the Code Blue stations is shown here. Please see standard Installation Manual for complete information.

Models:

- NHR-7A-CB1: standard unit (SPST)
- *NHR-7A-CB2: Includes second dry contact closure (DPDT)

OPERATIONS:

The NHX system with CODE BLUE has three priority levels:

Priority 1: Code Blue

Priority 2: Bath call and cord-out

Priority 3: Routine call

1. Code Blue call signal is a fast beep (1 per 0.5 seconds) and flashing LED (1 per 0.4 seconds).
This signal is activated when the blue call switch on the NHR-7A-CB1 is moved to the lower position, and will continue until it's reset to the upper position.
2. The Bath/Cord out signal is a single beep (1 per 2 seconds) and a double-blinking LED (2 blinks every 1.8 seconds). This signal is activated when the bath pull cord (NHR-7A) is moved to the lower position, or when the handheld call button (NHR-8A) is pulled out of the station. The call signal will remain until the master answers the call, at which time the tone will be reset. The blinking LED will remain until the bath station is reset to the upper position or the handheld call button is plugged back into the station.
3. The Routine call signal is a single beep (1 per 6 seconds) and a blinking LED (1 per 2 seconds). This signal is activated when the button is pressed on the handheld call cord, and is reset when the master station answers the call or when the CANCEL button on the patient station is pressed.
4. To place a CODE BLUE CALL, activate the Code Blue Station located near the patient station by pulling the attached cord or sliding the blue call switch down.
5. To reset the CODE BLUE CALL, move the blue call switch to the upper position.